

INVID-DDPB

NEMA Enclosure Weatherproof Box

- Air Breaker: Ensures safe circuit operation and protection against overloads or short circuits.
- Surge Protector: Guards against power surges, extending the lifespan of connected equipment.
- USA Power Plug: Standard power plug compatible with US outlets for seamless installation.
- MeanWell UL DC24V/5A Power Supply: Reliable and UL-certified power source for connected devices.
- Temperature Controller: Maintains optimal internal conditions to prevent overheating or freezing.
- UL Listed Fans: Certified cooling fans for efficient airflow and heat dissipation.
- PTZ Mount: Compatible with Pan-Tilt-Zoom (PTZ) cameras for versatile surveillance coverage.
- 70CM AC Wire with IP68 M12 Connector: Pre-assembled waterproof cable for secure and durable connections.
- UL AC Wire Fast Installation Connector: Simplifies wiring for faster and safer setups.
- 120W PCM: High-capacity power converter module for dependable power delivery.
- NPT 3/4" Knockout: Pre-punched knockout for convenient conduit installations.
- NPT 3/4" Male Screws: Sturdy connectors for secure fitting of conduits.
- PG21 & PG21 Connectors: Cable glands for sealing and protecting electrical connections.
- Dual Deterrence Lights: Integrated lights to enhance security and deter intruders.
- Wall & Pole Mount Capability: Flexible installation options for diverse mounting needs.
- Durable Clamps: Strong and adjustable clamps for stable and reliable mounting.
- M8-80 Stainless Steel Wall Mount Screws: Corrosion-resistant screws for long-lasting wall installations.



Quick Setup Pole Mounting

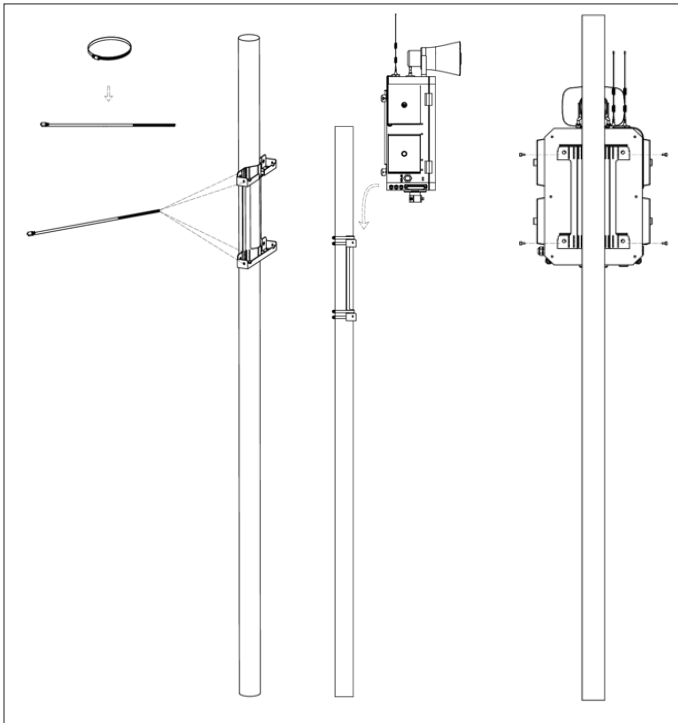

Quick Setup Wall Mounting

